

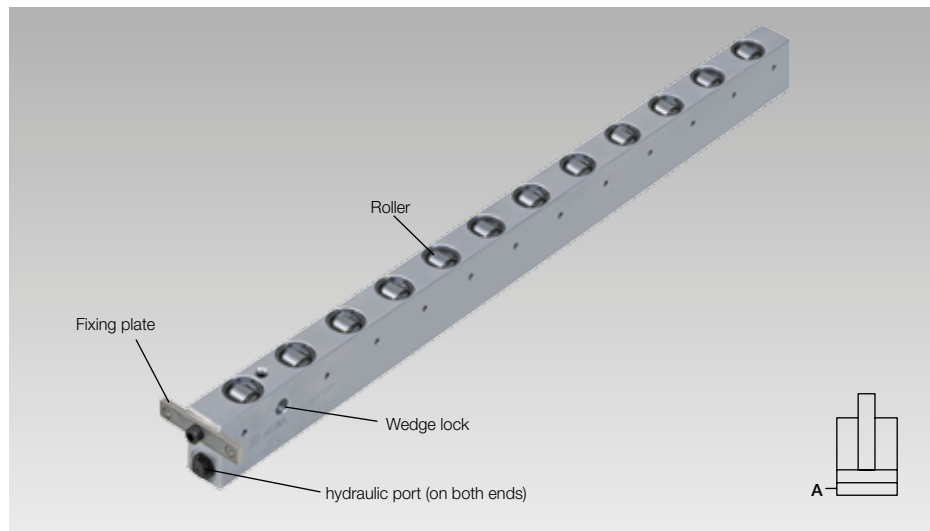

Roller Bars, Hydraulic

with lifting of the individual rollers

max. load 126 kN/m, max. operating pressure 120 bar



Advantages

- Easy and safe die change
- Variant program with many selection possibilities
- Hydraulic lifting of each individual roller
- Variable length in a single piece design up to 2900 mm
- Slot depth, roller spacing and bar length configurable for every application
- Low weight (version in aluminium)

Application

- In T-slots and rectangular slots of the press bed for easy die change without any problems
- Die change streamlining

Delivery

- Roller bar
- Fixing plate
- 90° swivel banjo coupling

Description

Roller bars with hydraulic lifting of the individual rollers for medium loads and linear movement of the dies.

Contrary to the roller bars as per data sheet WZ 8.18340, the lifting pistons are below each roller. Each roller is lifted individually. The base body remains in its position.

The die positioned on the rollers is not in contact with the table top and can be easily moved linearly and positioned.

T-slot tolerances as per DIN 650

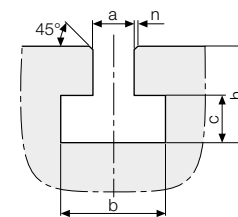

	a	b	c	h min.	h max.	n max.
18 H12	30 ⁺²	12 ⁺²	30	36	1.6	
22 H12	37 ⁺³	16 ⁺²	38	45	1.6	
28 H12	46 ⁺⁴	20 ⁺²	48	56	1.6	
36 H12	56 ⁺⁴	25 ⁺³	61	71	2.5	

Dimensions in mm

$h_{\min.}$ = minimum dimension as per DIN 650

Technical data

Max. operating pressure	[bar]	120
Max. load	[kN/m]	126
Roller spacing and orientation		flexible
Material of the bar		aluminium or steel
Max. temperature	[°C]	with aluminium bars: 100 with steel bars: 250
Fixing of the bar		fixing plate or wedge lock
Max. bar length*	[mm]	variable* up to 2900

* The minimum bar lengths depends on the roller spacing G with at least 3 rollers (see page 2)

Technical data • Dimensions

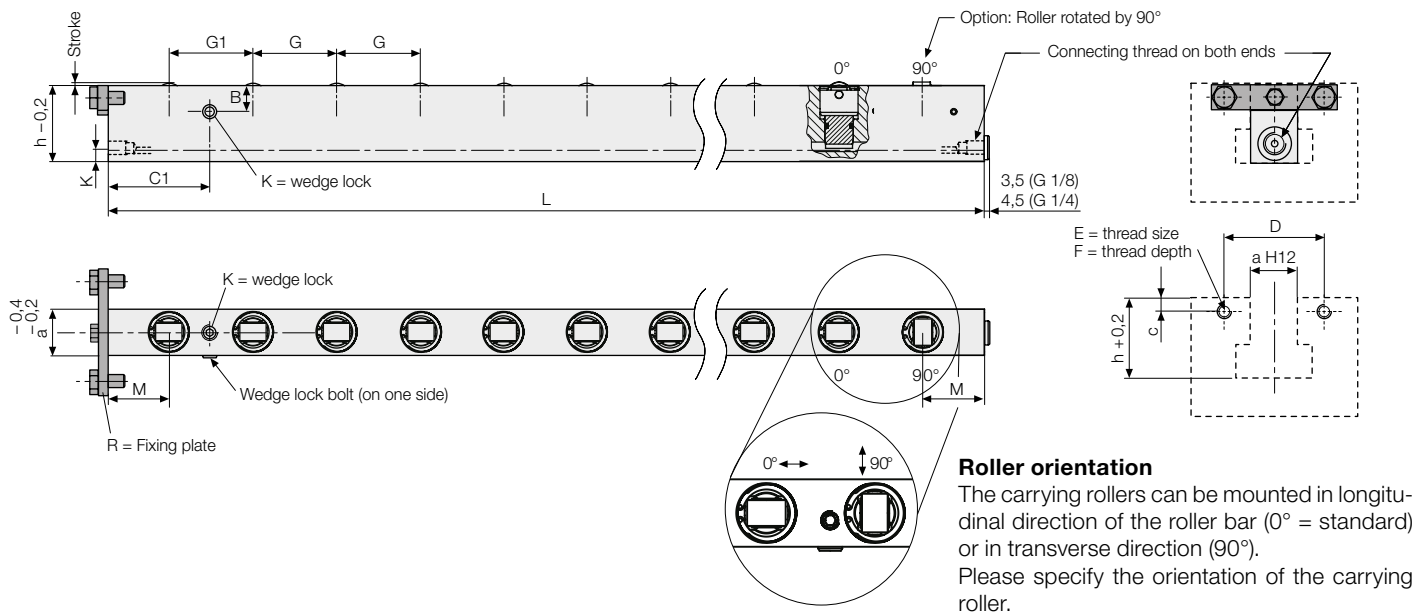

Roller orientation

The carrying rollers can be mounted in longitudinal direction of the roller bar (0° = standard) or in transverse direction (90°). Please specify the orientation of the carrying roller.

e.g. **X = 90°**

Technical data

Slot width (a)	[mm]	18	22	28	36	13/16"	1 1/16"
Slot depth min. (h)	[mm]	29.5	37.5	43	54.5	29.4	38
Slot depth standard (h)	[mm]	30	38	48	61	29.4	38.9
Slot depth max.** (h)	[mm]	45	55	60	75	40	58
Roller spacing G min.	[mm]	20	23	28	34	20	23
Roller spacing G1 min.	[mm]	26	32	37	43	26	32
Roller spacing G/G1 standard	[mm]	30	40	45	50	30	40
Roller spacing G/G1 max.	[mm]	60	80	90	100	60	80
L min.	[mm]	*)	*)	*)	*)	*)	*)
L max.	[mm]	2900	2900	2900	2900	2900	2900
Stroke	[mm]	1	2	2	2	1	2
Longer stroke	[mm]	-	-	3	3	-	-
Load/roller	[kN]	1.14	1.85	3.0	4.5	1.14	1.85
Connecting thread		G 1/8	G 1/8	G 1/4	G 1/4	G 1/8	G 1/4
Oil volume/roller insert	[cm³]	0.10	0.31	0.51	0.76	0.10	0.31
B	[mm]	12	16	16	16	12	16
C	[mm]	5	7	9	10	5	7
C1	[mm]	35	46	51	56.5	35	46
D	[mm]	36	40	50	55	36	40
E	[mm]	M5	M5	M6	M6	M5	M5
F	[mm]	8	8	12	12	8	8
K	[mm]	8	8.5	11	11	8	11
M	[mm]	22.5	30	32.5	35	22.5	30

*) L min. depends on the roller spacing G with at least 3 rollers

**) only with steel bars

Fixing plate and 90° elbow coupling are included in the delivery.

Product configurator

For the selection and configuration of roller and ball bars, a product configurator is available on our website.

After entering the parameters, the configurator determines the desired roller or ball bars with all technical data and the identification number of the characteristics which are identical with the order number. In addition, a drawing with all dimensions will be provided.

Link to the configurator:

www.roemheld-gruppe.de/productconfigurator/?lang=en



Code for part numbers Variant program

Roller bars with hydraulic lifting are individually configured and manufactured depending on the application. Within the limits specified in the measurement chart, the following parameters can be selected based on a code for part numbers: **bar material, slot width, bar lengths, fixation, slot depth, roller spacing and roller orientation.**

• Stroke

The roller bar is equipped with standard stroke (1 or 2 mm). For slot width 28 and 36, alternatively a larger stroke of 3 mm is available.

• Bar material/operating temperature

Aluminium or steel can be selected as bar material. For operating temperatures >100 °C, a steel version is required. Depending on the temperature range, the admissible carrying force of the roller bars is reduced:

- up to 100 °C: 100 % of the carrying force
- > 100 – 150 °C: 95 % of the carrying force
- > 150 – 200 °C: 70 % of the carrying force
- > 200 – 250 °C: 60 % of the carrying force

e.g. steel up to 200 °C with 70 % of the carrying force

• Slot width (a)

Selection from the table on page 2

e.g. a = 28 mm

• Bar lengths (L)

Depending on the roller spacing (G) and the parameter (M) results the possible bar length. Indicate the desired length (e.g. bed length) for your roller bar. Please note that a roller bar must be equipped with at least 3 rollers.

e.g. L = 1445 mm

• Fixation

K = wedge lock
R = fixing plate

e.g. fixing plate = R

• Roller spacing (G) or load of the bar

By changing the spacing of the rollers, the load of the roller bar can be varied. Please note that the load is indicated for the full length of the bar. Therefore, both the load and the roller spacing must be selected to suit the die weight and the die supporting length.

Please indicate the desired roller spacing or load of the ball bar, or the maximum die weight and the die dimensions.

Note for the calculation of the bar length

The spacing of the first two rollers G1 is limited by the position of the wedge lock.

The following applies: $G = G1$, however when selecting $G < G1$ min the spacing G1 will not be reduced below the minimum value.

e.g. G = 60 mm

or **load per bar = 72 kN**

or **number of rollers = 24**

or **die weight and exterior dimensions**

• Slot depth (h)

If the slots in your application are lower than the default value, specify the corresponding dimension (up to h min.) For slots which are deeper than the default value, spacer bars can be inserted. For steel versions, specify the corresponding dimension (up to h max.).

e.g. h = 43 mm

• Roller orientation

The carrying rollers can be mounted in longitudinal direction of the roller bar (0° = standard) or in transverse direction (90°). Please specify the orientation of the carrying roller.

e.g. X = 90°

Code for part numbers

Variant program

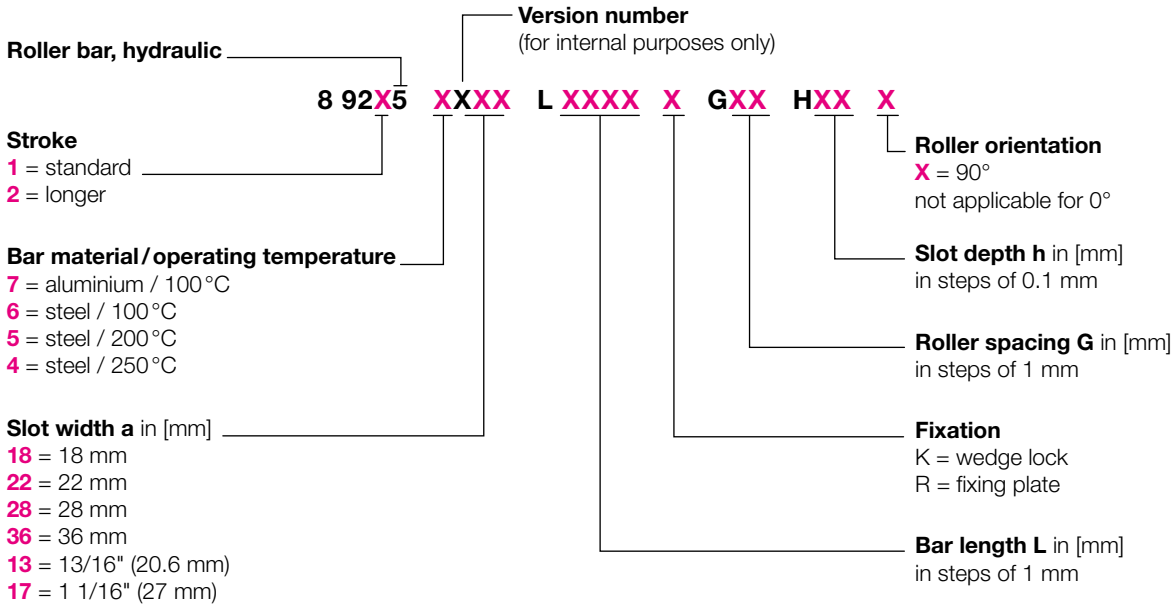

Page 4 shows an example of the part numbers for aluminium bars with standard roller spacing "G" and standard slot depth "h".

Example of ordering

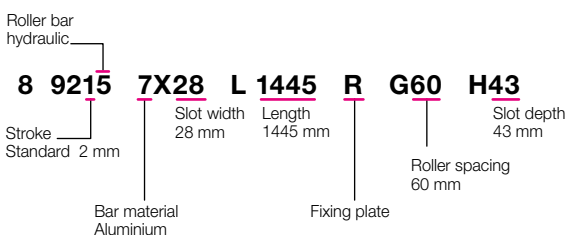

Extract from the possible variants for roller bars
with standard roller spacing "G", standard slot depth "h" and bar material aluminium

for slot width a = 18 mm

Length (L) [mm]	Load [kN]	Number of rollers	Part no.
105	3.4	3	89215 7018 L 105 R
135	4.5	4	89215 7018 L 135 R
165	5.7	5	89215 7018 L 165 R
195	6.8	6	89215 7018 L 195 R
255	9.1	8	89215 7018 L 255 R
315	11.4	10	89215 7018 L 315 R
375	13.6	12	89215 7018 L 375 R
435	15.9	14	89215 7018 L 435 R
495	18.2	16	89215 7018 L 495 R
555	20.5	18	89215 7018 L 555 R
615	22.8	20	89215 7018 L 615 R
675	25.0	22	89215 7018 L 675 R
735	27.3	24	89215 7018 L 735 R
795	29.6	26	89215 7018 L 795 R
855	31.9	28	89215 7018 L 855 R
915	34.2	30	89215 7018 L 915 R
975	36.4	32	89215 7018 L 975 R
other lengths are possible up to max. 2895			
2895	109.4	96	89215 7018 L 2895 R

for slot width a = 22 mm

Length (L) [mm]	Load [kN]	Number of rollers	Part no.
140	5.5	3	89215 7022 L 140 R
180	7.4	4	89215 7022 L 180 R
220	9.2	5	89215 7022 L 220 R
260	11.1	6	89215 7022 L 260 R
340	14.8	8	89215 7022 L 340 R
420	18.5	10	89215 7022 L 420 R
500	22.2	12	89215 7022 L 500 R
580	25.9	14	89215 7022 L 580 R
660	29.6	16	89215 7022 L 660 R
740	33.3	18	89215 7022 L 740 R
820	37.0	20	89215 7022 L 820 R
900	40.7	22	89215 7022 L 900 R
980	44.4	24	89215 7022 L 980 R
1060	48.1	26	89215 7022 L 1060 R
1140	51.8	28	89215 7022 L 1140 R
1220	55.5	30	89215 7022 L 1220 R
1300	59.2	32	89215 7022 L 1300 R
1380	62.9	34	89215 7022 L 1380 R
other lengths are possible up to max. 2900			
2900	133.2	72	89215 7022 L 2900 R

for slot width a = 28 mm

Length (L) [mm]	Load [kN]	Number of rollers	Part no.
155	9	3	89215 7028 L 155 R
200	12	4	89215 7028 L 200 R
245	15	5	89215 7028 L 245 R
290	18	6	89215 7028 L 290 R
380	24	8	89215 7028 L 380 R
470	30	10	89215 7028 L 470 R
560	36	12	89215 7028 L 560 R
650	42	14	89215 7028 L 650 R
740	48	16	89215 7028 L 740 R
830	54	18	89215 7028 L 830 R
920	60	20	89215 7028 L 920 R
1010	66	22	89215 7028 L 1010 R
1100	72	24	89215 7028 L 1100 R
1190	78	26	89215 7028 L 1190 R
1280	84	28	89215 7028 L 1280 R
1370	90	30	89215 7028 L 1370 R
other lengths are possible up to max. 2900			
2900	192	64	89215 7028 L 2900 R

for slot width a = 36 mm

Length (L) [mm]	Load [kN]	Number of rollers	Part no.
170	13.5	3	89215 7036 L 170 R
220	18	4	89215 7036 L 220 R
270	22.5	5	89215 7036 L 270 R
320	27	6	89215 7036 L 320 R
420	36	8	89215 7036 L 420 R
520	45	10	89215 7036 L 520 R
620	54	12	89215 7036 L 620 R
720	63	14	89215 7036 L 720 R
820	72	16	89215 7036 L 820 R
920	81	18	89215 7036 L 920 R
1020	90	20	89215 7036 L 1020 R
1120	99	22	89215 7036 L 1120 R
1220	108	24	89215 7036 L 1220 R
1320	117	26	89215 7036 L 1320 R
1420	126	28	89215 7036 L 1420 R
other lengths are possible up to max. 2870			
2870	256.5	57	89215 7036 L 2870 R

for slot width a = 13/16"

Length (L) [mm]	Load [kN]	Number of rollers	Part no.
105	3.4	3	89215 7013 L 105 R
135	4.5	4	89215 7013 L 135 R
165	5.7	5	89215 7013 L 165 R
195	6.8	6	89215 7013 L 195 R
255	9.1	8	89215 7013 L 255 R
315	11.4	10	89215 7013 L 315 R
375	13.6	12	89215 7013 L 375 R
435	15.9	14	89215 7013 L 435 R
495	18.2	16	89215 7013 L 495 R
555	20.5	18	89215 7013 L 555 R
615	22.8	20	89215 7013 L 615 R
675	25.0	22	89215 7013 L 675 R
735	27.3	24	89215 7013 L 735 R
795	29.6	26	89215 7013 L 795 R
855	31.9	28	89215 7013 L 855 R
915	34.2	30	89215 7013 L 915 R
975	36.4	32	89215 7013 L 975 R
other lengths are possible up to max. 2895			
2895	109.4	96	89215 7013 L 2895 R

for slot width a = 1 1/16"

Length (L) [mm]	Load [kN]	Number of rollers	Part no.
140	5.5	3	89215 7017 L 140 R
180	7.4	4	89215 7017 L 180 R
220	9.2	5	89215 7017 L 220 R
260	11.1	6	89215 7017 L 260 R
340	14.8	8	89215 7017 L 340 R
420	18.5	10	89215 7017 L 420 R
500	22.2	12	89215 7017 L 500 R
580	25.9	14	89215 7017 L 580 R
660	29.6	16	89215 7017 L 660 R
740	33.3	18	89215 7017 L 740 R
820	37.0	20	89215 7017 L 820 R
900	40.7	22	89215 7017 L 900 R
980	44.4	24	89215 7017 L 980 R
1060	48.1	26	89215 7017 L 1060 R
1140	51.8	28	89215 7017 L 1140 R
1220	55.5	30	89215 7017 L 1220 R
1300	59.2	32	89215 7017 L 1300 R
1380	62.9	34	89215 7017 L 1380 R
other lengths are possible up to max. 2900			
2900	133.2	72	89215 7017 L 2900 R

Fixing plate = **R**
Wedge lock = **K**