



Clamping Nuts, Mechanical

with through-hole thread, without clamping force display



Advantages

- Temperature resistance up to 200 °C
- High clamping force with low torque
- Easy to retrofit
- Clamping nut with through-hole thread, therefore high adaptability to varying heights of clamping edges and tolerances
- Easy clamping and unclamping by hand
- Hydraulic-free and maintenance-free clamping
- Maximum force density in the smallest space

Application example

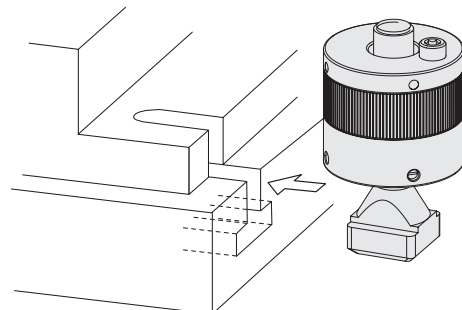

Application

- Clamping and locking of dies on press bed and ram
- When highest clamping force is required in the smallest possible space
- If no hydraulic power unit is available
- Where oil-free clamping is desired

Description

Following manual positioning of the clamping nut against the clamping edge, the integral gear nut will be operated by turning the hexagon socket. As a result of the gear transmission, the tightening torque is multiplied. To reliably ensure the required clamping force, we recommend using a torque wrench.

Material: free cutting steel, nitrocarburized

Temperature range: -30 °C to +200 °C

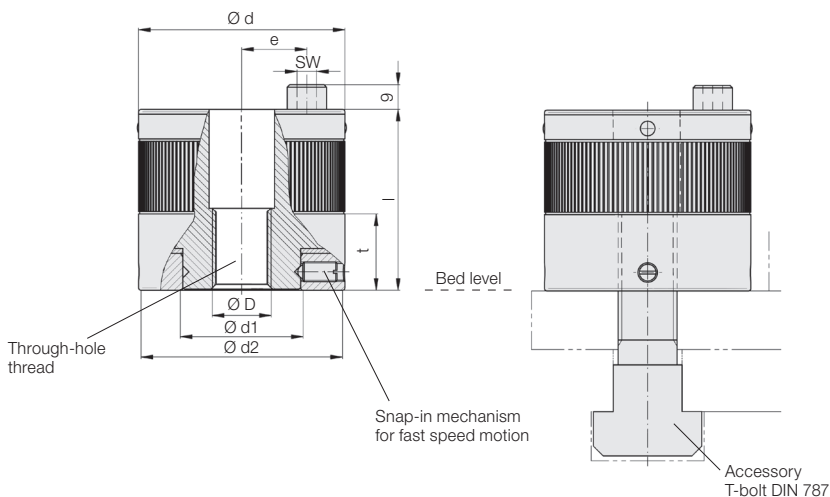

Technical data

T-slot DIN 650	[mm]	14	18	22	28	36	42
Clamping force	[kN]	60	60	60	120	180	180
Tightening torque	[Nm]	20	35	40	75	100	110
D	[mm]	M12	M16	M20	M24	M30	M36
d	[mm]	74	74	74	84	105	105
d1	[mm]	40	40	40	50	64	64
d2	[mm]	72	72	72	82	103	103
l	[mm]	58	58	58	74	78	78
t	[mm]	23	23	23	32	37	37
SW	[mm]	8	8	8	8	8	8
Clamping nut without T-bolt							
Weight, approx.	[kg]	1.6	1.6	1.6	2.5	3.9	3.8
Part no.		822750005	822750006	822750007	822760004	822770004	822770005
T-bolt, separate		M12x14x200	M16x18x125	M20x22x160	M24x28x160	M30x36x250	M36x42x250
Part no.		107871210*	107871169	107870211	107871246	107870304	107870308

Additional sizes as well as variations in the thread sizes are available on request.

* For T-slot 14 mm, required strength 12.9

Accessory

Torque wrench 20 – 100 Nm

Part no. 937926610

Torque wrench 40 – 200 Nm

Part no. 937926620